

LED Troffer

Pre-Select 3 Wattage & 4 CCT



Features

- 2X2 / 2X4
- 120-347V/60Hz
- 135 lm/W
- Dimming 0-10V
- Die formed of 0.6mm cold-rolled steel body
- Fully recessed luminaire fits standard T-Grid ceilings
- High-diffusion light-milky PC diffuser
- 5-Year Warranty
- 5.1 DLC Premium
- DLC No.: S-763ZJM / S-0D9H58
- Application: school, hospital, super market, office and warehouse, etc.
- Microwave Motion Sensor (Optional)

Dimensions

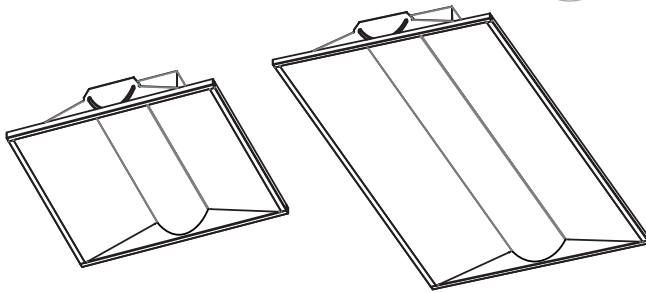

SKU	LxWxH
SKU#112101 2 X 2	603x603x55 (mm) 23.74"x23.74"x2.17"
SKU#112102 2 X 4	1213x603x55 (mm) 47.76"x23.74"x2.17"

Specifications

SKU	Pre-Select Wattage	Input Voltage	Luminous Flux	Luminous Efficacy	CCT	THD	Input Current	Beam Angle	CRI	PF	Surge Protection	Operating Temperature
SKU#112101 2X2	20W/30W/35W	AC120-347V	2700 lm 4050 lm 4725 lm	135 lm/W	3000K 3500K 4000K 5000K	≤20%	0.5A @120 Vac	120°	>80	>0.9	L-N 1KV L&N-G 2KV	-20°C~ +50°C
SKU#112102 2X4	30W/40W/50W		4050 lm 5400 lm 6750 lm									

Pre-Select 3 Wattage & 4 CCT

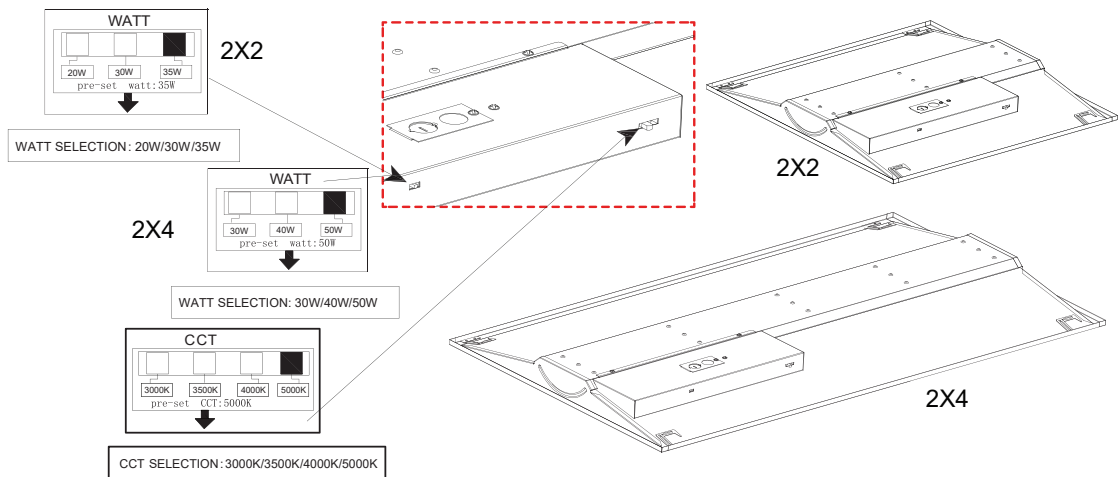

LED Troffer

Pre-Select 3 Wattage & 4 CCT

Test Report

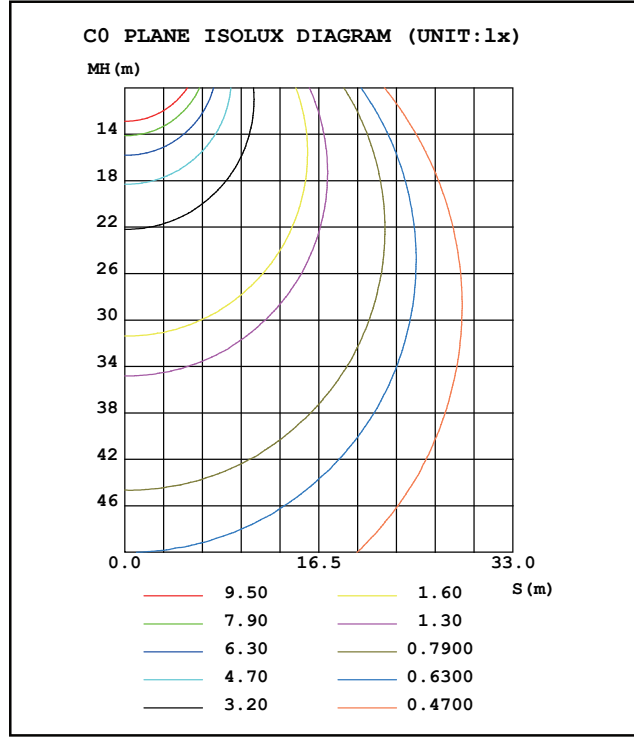
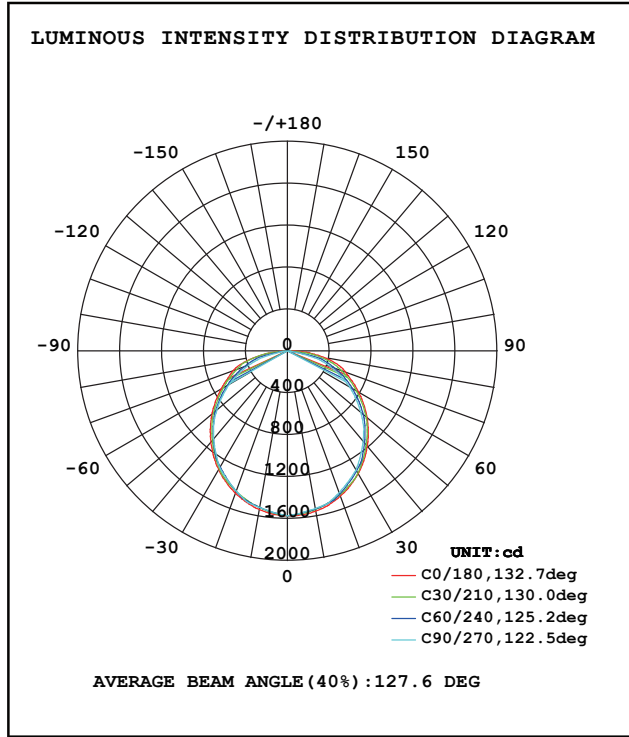

Application

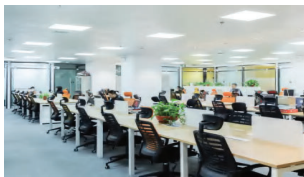

Office



Bank



Library

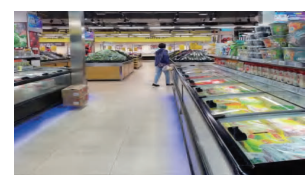

Supermarket

Optional Accessories



#SKU100889

Microwave Motion Sensor for Linkable Strip (SKU#100886), LED Eco-Commercial & Industrial Strip (SKU#100891 & SKU#100892) and LED Troffer Light (SKU#112101 & SKU#112102); Programmable by Controller (SKU#100890)



#SKU100889

Remote Controller for Microwave Motion Sensor (SKU#100889)