

Pre-Select 5 CCT LED Flush Mount with PIR Motion Sensor & Photocell

FDFM-7-15W-5CCT-120V-D-PIR-WH
SKU#101093
FDFM-9-18W-5CCT-120V-D-PIR-WH
SKU#101095
FDFM-12-24W-5CCT-120V-D-PIR-WH
SKU#101097



- Switchable between Day Mode and Night mode
- 1. Day mode: 100% light output at the day and night time whenever motion is detected
- 2. Night mode: Turns the light ON when motion is detected and the space light intensity is < 50lux

Features

- Dims to 30% after 30 Second/ 3 minute / 5 minute
- Integrated PIR Sensor
- Edge-lit technology, no glare or dark spots, instant-on
- This 0.7" thick luminaire is easy to install on standard Junction boxes with a quick snap
- Construction: PC lamp body with white translucent acrylic lens
- Suitable for WET LOCATION
- Life span - over 50,000 hours
- Pre-Select 5 CCT-2700K, 3000K, 3500K, 4000K, 5000K

5-CCT Selectable

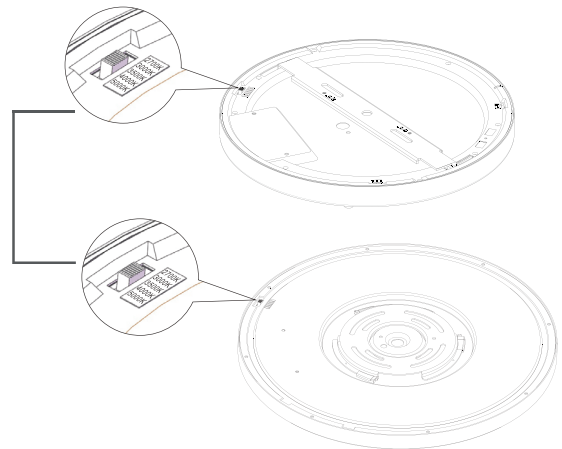

PIR Motion Sensor + Photocell Sensor

1. PIR Motion Sensor: Automatically turn to standby mode when people walk out of the reaction range. When motion is detected, is automatically turns lights 100% ON, and dims down after 30 seconds / 3 minutes / 5 minutes delay if no more motion.
2. Photocell Sensor: No manual operation is required. Detecting ambient light changes and automatically turns the lighting output to 30% or 100%.

How it works

	Standby Mode Standby when the environment is too bright to trigger photocell.		Standby Mode The light won't turn 100% at night time without motion detected.
	Standby Mode The light won't turn on at day time even there is motion detected.		Working Mode Automatically turns 100% at night time when motion is detected and dims down when the space is vacated.

SPECIFICATION			
Watts	15W	18W	24W
Lumen	1017lm	1363lm	1850lm
Color Temperature	Pre-Select 5 CCT 2700K, 3000K, 3500K, 4000K, 5000K		
CRI	CRI 90+		
Input	AC120V,60Hz		
Dimming	Dim to 30% by Sensor		
Power Factor	>0.9		
Wet Location	Yes		
Air Tight	Yes		
OperatingTemp.	-20°C~+40°C (-4°F~104°F)		
Beam Angle	110°		

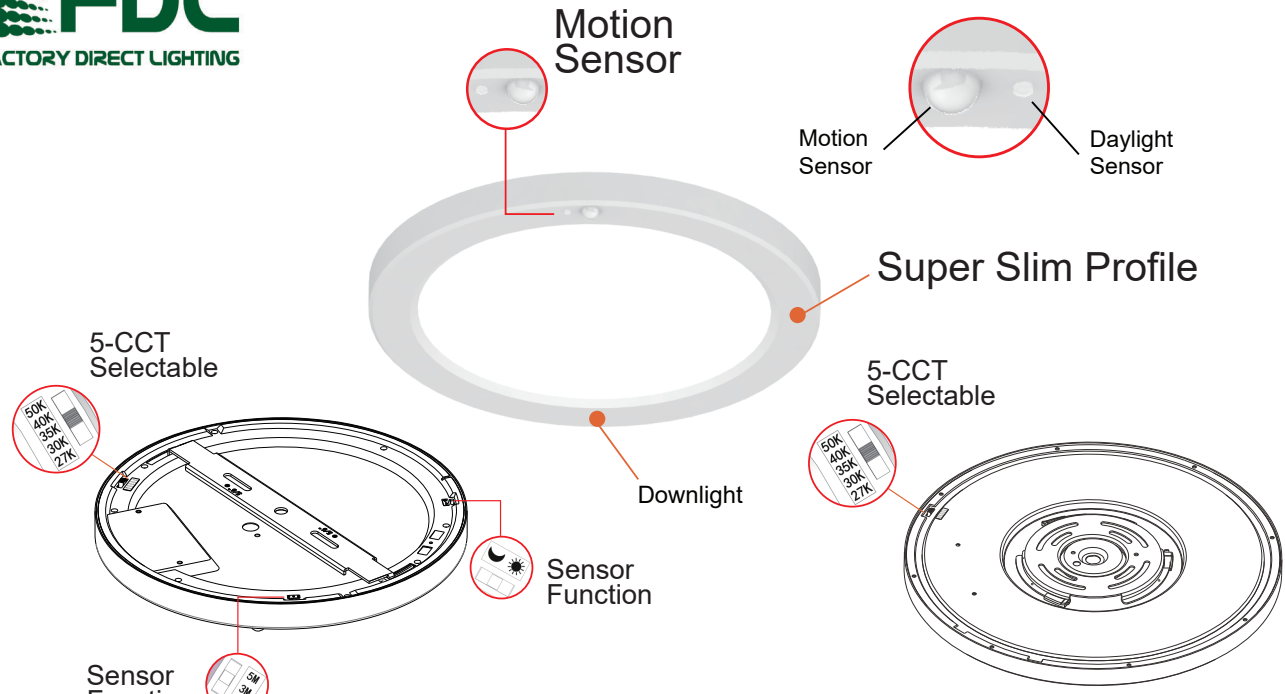

CAN CONVERTER (Optional Accessories)

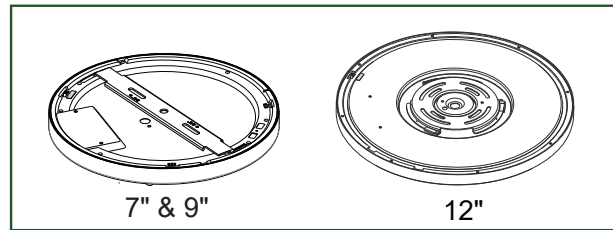
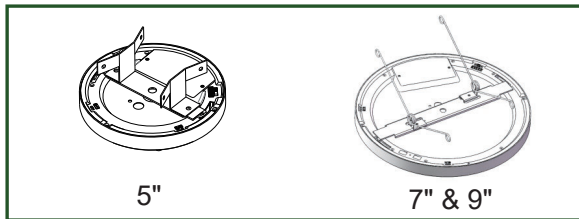

PIR Motion Function

Can select delay time 30 sec/3 min/5 min.

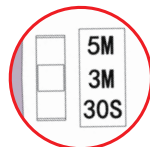

30S/3M/5M sensor duration time setting

Photocell Function

Turn on by Night Mode.
Turn off by Day Mode.

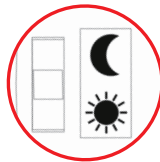

Daylight sensor Switch

NIGHT MODE			
NIGHTLIGHT (Ambient light \leq 50 lux)			
Approx.30% Output	Detected 100% Output	Not Detected Delay 0.5 min/ 3min/5min. 100% Output	Not Detected Approx. 30%
DAYLIGHT			
Approx.30% Output	Detected 30% Output	Not Detected Delay 0.5 min/ 3min/5min. 30% Output	Not Detected Approx. 30%

DAY MODE			
ALLDAY			
Approx.30% Output	Detected 100% Output	Not Detected Delay 0.5 min/ 3min/5min. 100% Output	Not Detected Approx. 30%

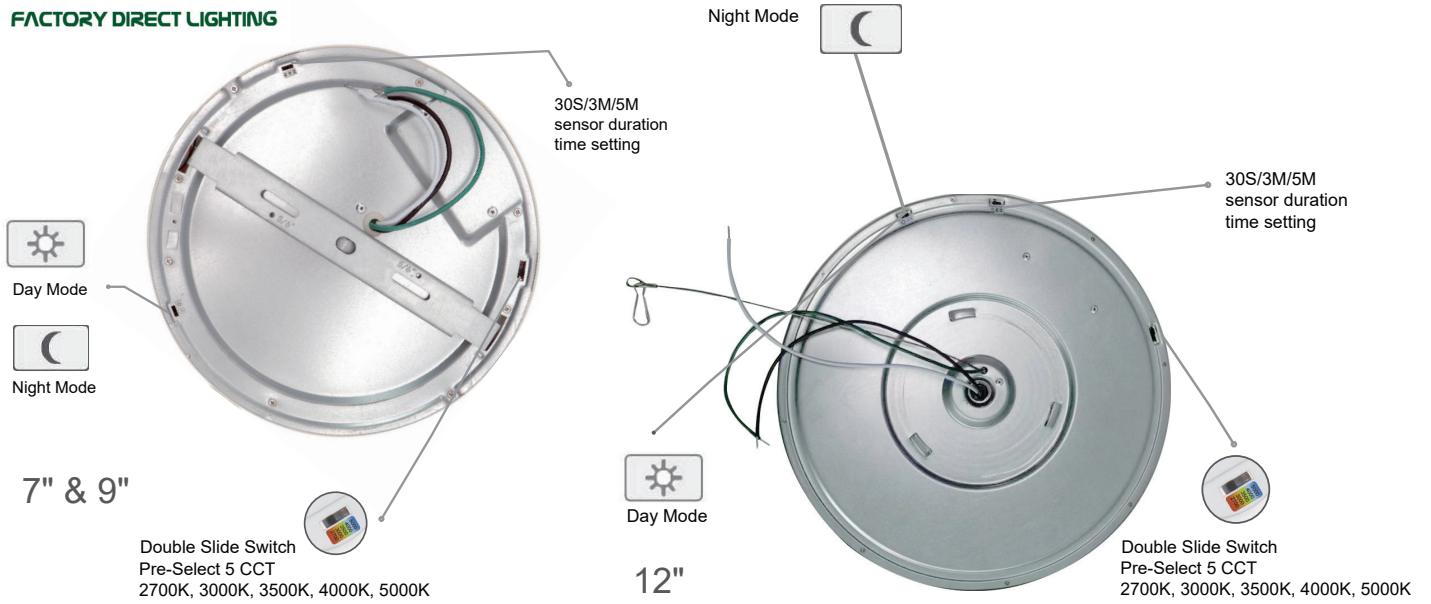

DIMENSION

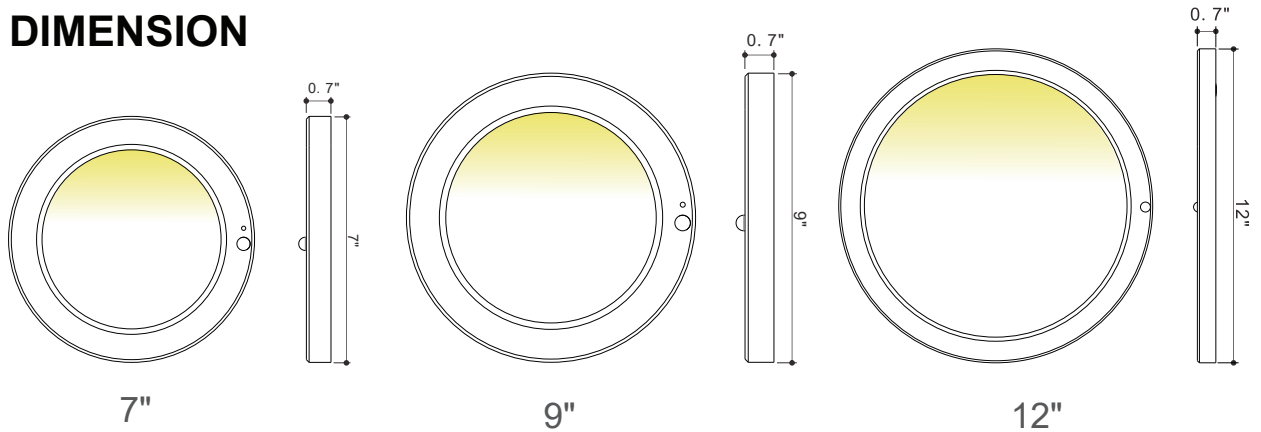

INCLUDED IN BOX

- 7" / 9" / 12" Plastic Round Slim Surface
- Two Mounting Screws
- Three Wire Connectors



Mounting Screws



Wire Connectors

Optional Accessories for 7" & 9" Fixture

- Two Screws
- E26 Adapter
- Two Mounting Clips
- LED Adapter



Optional Accessories
(Suitable for 7" & 9" Fixture)

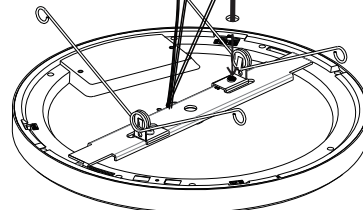

INSTALLATION

7" & 9"

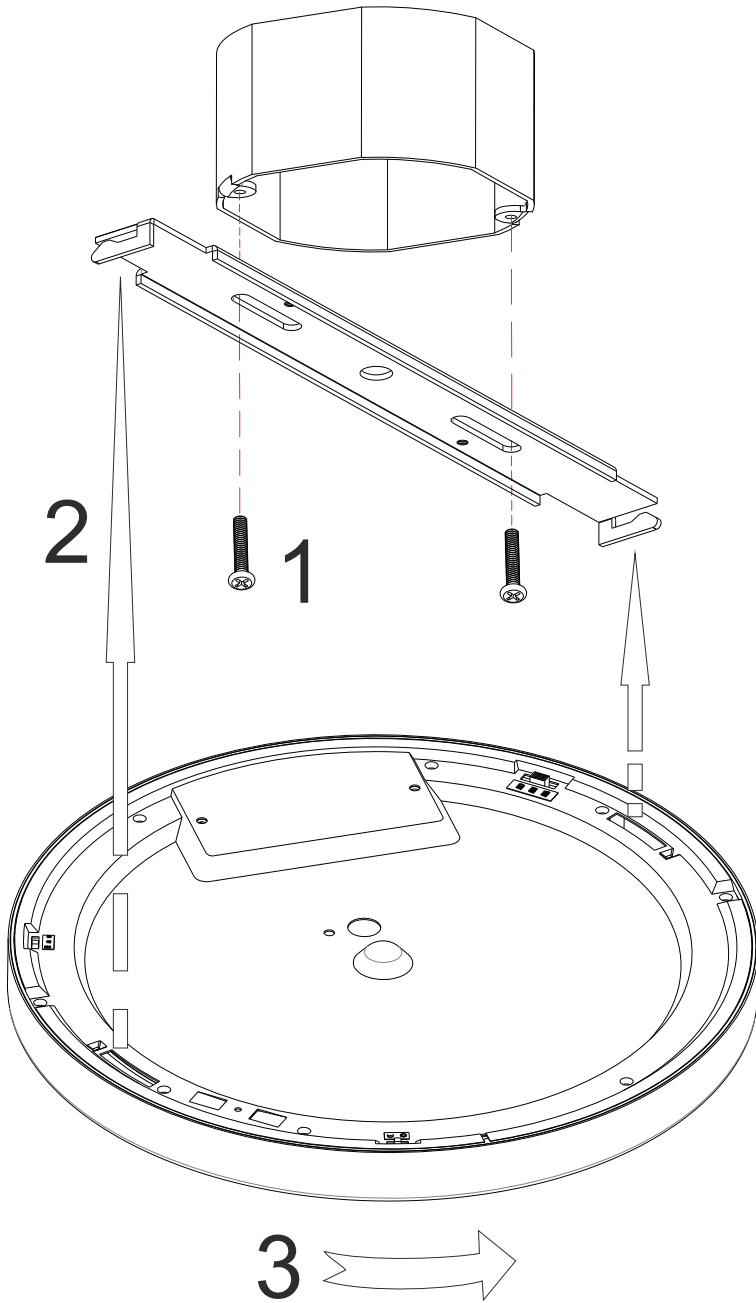

1

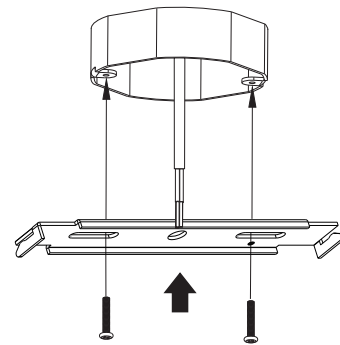

Secure base plate

- a. Use tapered tapping screws for solid ceiling
- b. Use flat head screws for wire boxes

2

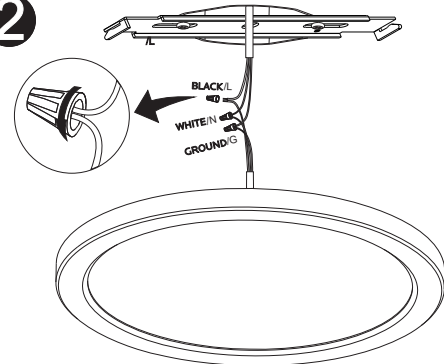

Connect the AC cables, L/N and G

- a. Black connect the L cable
- b. White connect the N cable
- c. Green connect the G cable

3

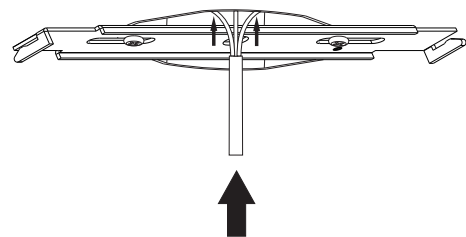

Push Wire Nutes upwards

Installation of Spring Clips (Optional Accessories)

7" & 9"

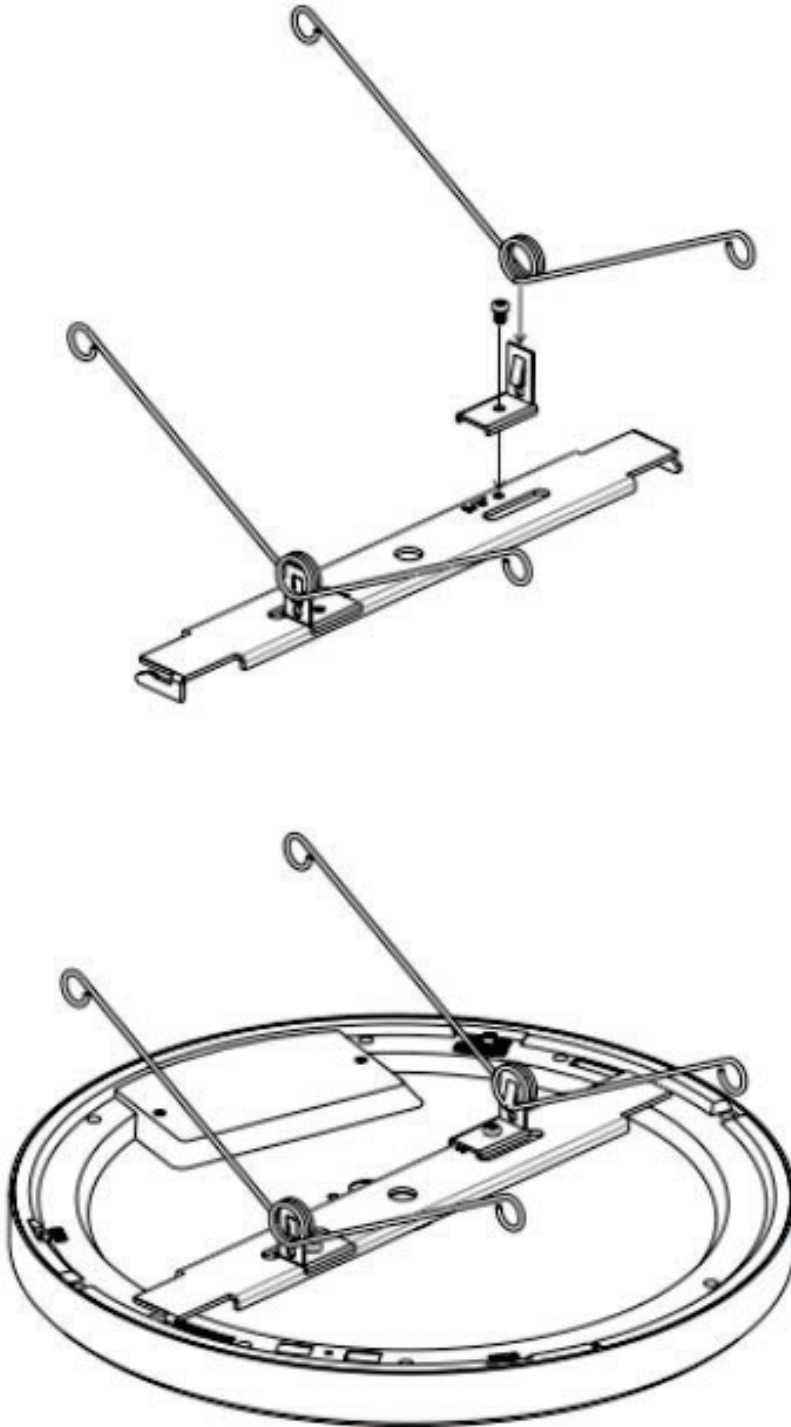

12"

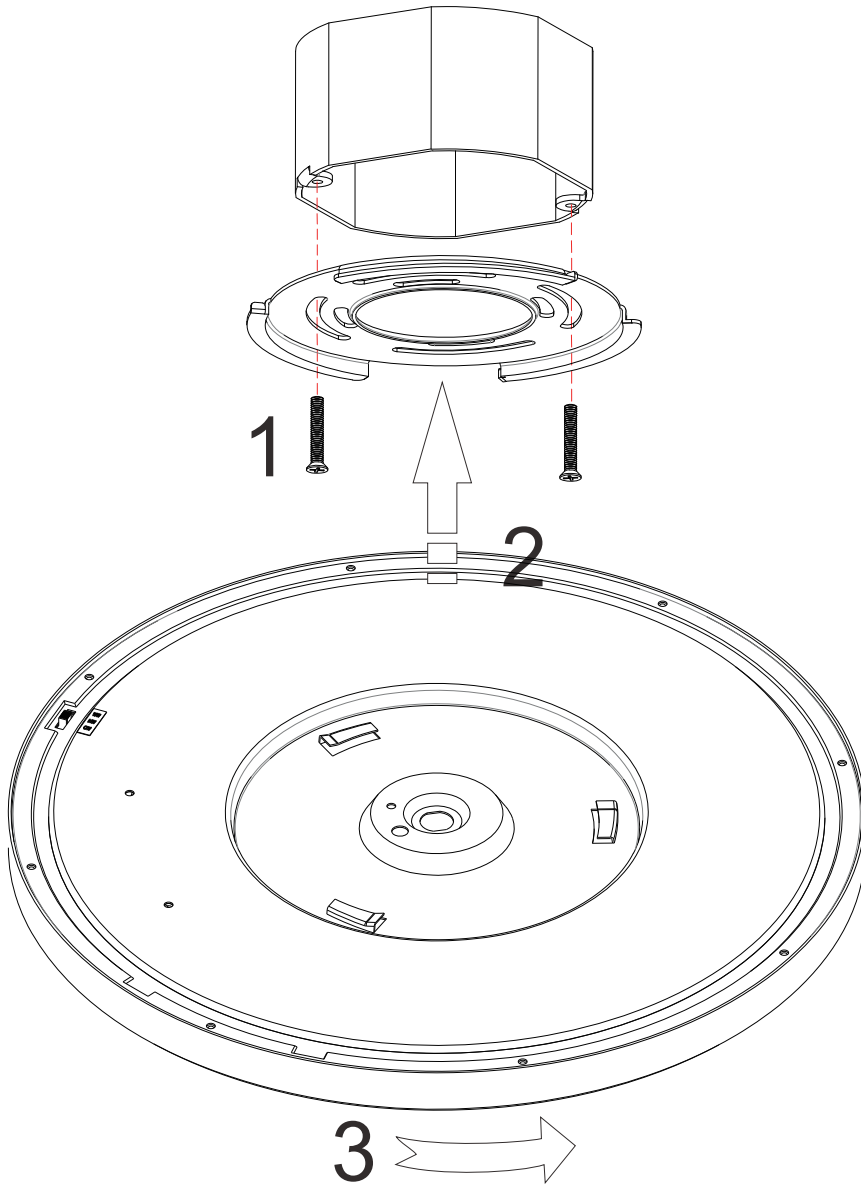

1

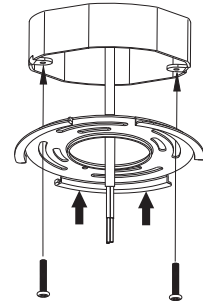

Secure base plate

- a. Use tapered tapping screws for solid ceiling
- b. Use flat head screws for wire boxes

2

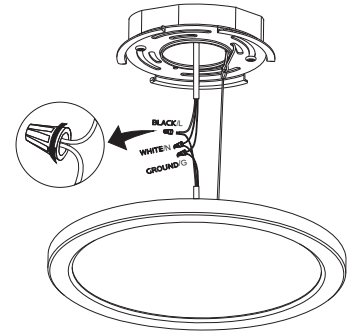

Connect the AC cables, L/N and G

- a. Black connect the L cable
- b. White connect the N cable
- c. Green connect the G cable

3

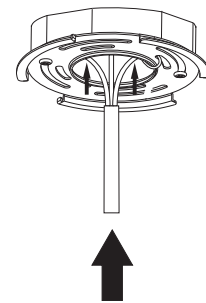

Push Wire Nutes upwards