



LED Mini Wall Pack - 13 watts with photo cell

SKU#104000





LED Mini Wall Pack with brand new design has upgraded for security lighting, it's widely used at pathway, hallway, perimeter, patio, entrance, stairway, house, garden, garage, yard, warehouse, factory, store, street, porch. With premium driver and Dust-to-Dawn photocell, save up to 80% on energy and oprating cost. Inside with 50000-hour Lumileds LED chipset as light sources, it's ideal solution to replace conventional fixtures.

- Dusk-to-Dawn photocell available - Auto turn on at dusk and off at dawn
- Unique slim shape design - Uniform lighting distribution via PC lens
- Easy and fast installation - Direct mounting on wall or with J-Box
- High efficiency output - light efficiency is up to 120LPW
- Waterproof IP65 rating - suitable for all kinds of weather
- Good energy saving - save 80% electricity cost compared to traditional lamp
- 5 Years Warranty for whole fixture and power supply



Specifications

| | |
|-------------------------------------|---|
| Item No. | FDWPS-13-LED-5K-120-277V |
| System Power(±5%) | 12.8 W |
| Electrical Data | |
| Input Voltage | 100-277 VAC |
| LED Driver | MINGLIGHT Driver |
| Power Frequency | 50/60Hz |
| Power Factor | >0.9 |
| THD | <20% |
| Optical Data | |
| System Efficacy | 137.8 (±5%) Lm/W tested based on 5000K Ra70 |
| Luminous Flux (±5%) | 1765LM |
| LED Chip | Lumileds SMD3030 |
| Beam Angle | 110° |
| Light Color | 5000K |
| CRI | >70 Ra |
| UGR | <19 |
| Temperature Data | |
| IP Rate | IP65 Rated |
| Operating Temp | -40° ~ 131° F (-40° ~ 55° C) |
| Ambient Temp | -4° ~ 104° F (-20° ~ 40° C) |
| Storage Temp | -40° ~ 158° F (-40° ~ 70° C) R.H.≤85% |
| Lifespan | ≥50000Hrs (Ta=30°C@L70) Operating |
| Fixture Material | Die casting Aluminium body |
| Safety Certification | ETL, DLC |
| Warranty | 5 Years |
| Dimension & Packing Data | |
| Product size (LxWxH) | 207.1 x 136.1 x 63.5mm (8.15" x 5.36" x 2.5") |
| Net Weight (Carton) | 10.5 KGS (23.15 LBS) |
| Gross Weight (Carton) | 11 KGS (24.25 LBS) |
| Carton size (LxWxH) | 74 x 30.5x 23cm (29.13" x 12" x 9.06") |
| Qty/Carton | 20 PCS |

| | |
|---------------------------------------|-----|
| L.E.D. vs HPS / MH Equivalence | |
| LED | 13W |
| HPS / MH | 50W |

Dimensions

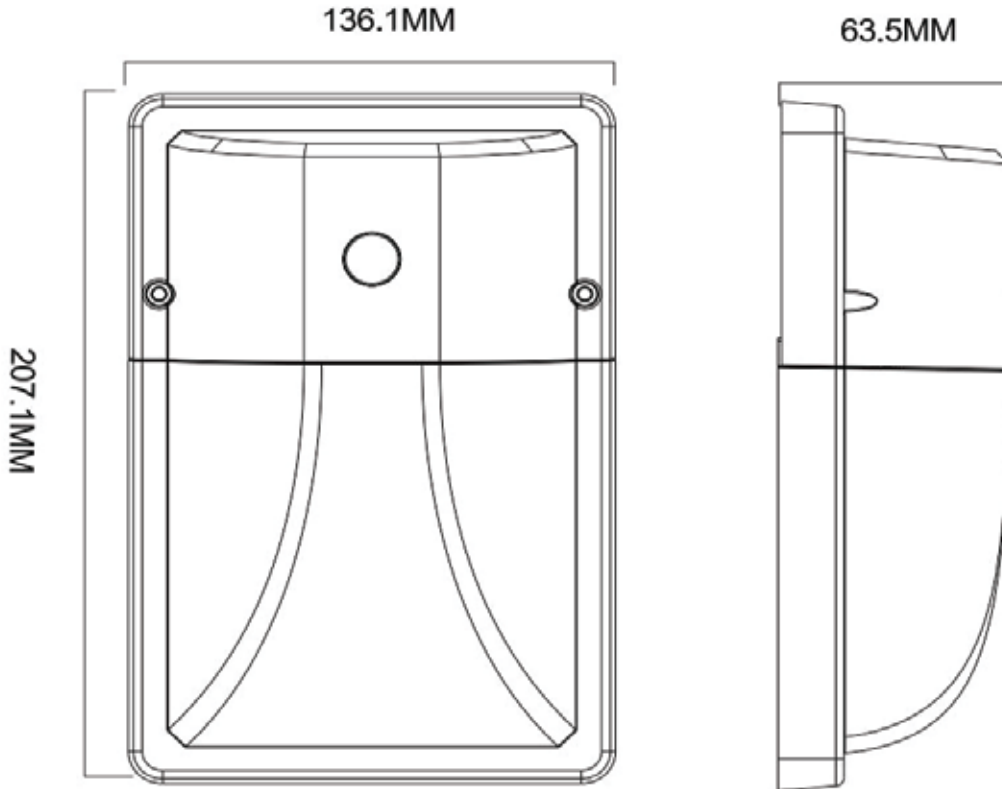

Installation Diagram

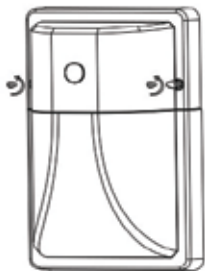

1. Install the cross screw

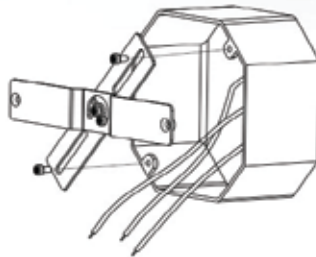

2. Install back plate to junction box

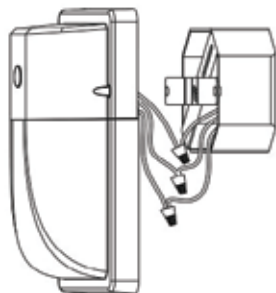

3. Connect wire

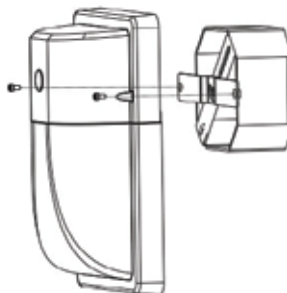

4. Install the fixture body and screw

Technical Specifications

#Certificate

RoHS approved

This product is tested by independent lab. with all green material.

ETL / DLC approved

This product have passed ETL testing and is fully DLC approved.

IESNA LM-79 and LM-80 Testing

FDL fixture have been tested by independent lab. in accordance with IESNA LM-79 and LM-80 Testing

Color Stability:

LED color temperature is warranted to shift no more than 200K in CCT over a 50000 hours.

Color Uniformity:

FDL's range of CCT follows the guidelines of the American National standard for specification for the chromaticity of Solid State Lighting (SSL) Products, ANSI C78.377-2017

#Installation

IES Classification:

80° beam angles, the lighting output produces a oval shape distribution to cover the area.

Mounting:

This product is direct mounting on wall mounting or with J-box The application including Warehouse, patio, entrance, stairway, house, Garage, outdoor facilities.

#LED Characteristics

Lifespan

50000 hours LED lifespan based on IES LM-80 results and TM-21 Calculation.

Color Consistency

7-step MacAdam Ellipse binning to achieve consistent one by one color.

#Smart Engine

Dimming Driver

1-10V Dimming optional

Smart Sensor

Built-in Photocell

#IP Rating

Ingress Protection rating of IP65 IP65 for dust and water

Greenity:

Mercury or UV free. RoHS compliant components. Package boxes are made with recyclable material.

#Smart solution

| Description | Pictures | Function |
|-------------|---|--|
| Photocell |  | Auto turn on at dusk/night and off at dawn/daytime |

#Trouble Shooting

| Problem | Possible Cause | Solutions |
|-----------------------|---|----------------------------|
| LEDs stop working | The power line is improperly connected. | Reconnect the power cable. |
| | The power plug is loose. | Firmly plug the power in. |
| | The LED driver malfunctions. | Replace with new driver. |
| | The LED chip is damaged. | Replace with new LEDs. |
| LEDs flash on and off | The output of the driver is abnormal. | Replace with new driver. |
| | The LED chip breaks down. | Replace with new LED chip. |

#Warranty

FDL warrants that our LED products will be free from defect in material and workmanship for a period of 5 years from the data of delivery to the end user including coverage of light output, color stability, driver performance and fixture.

Photometrics

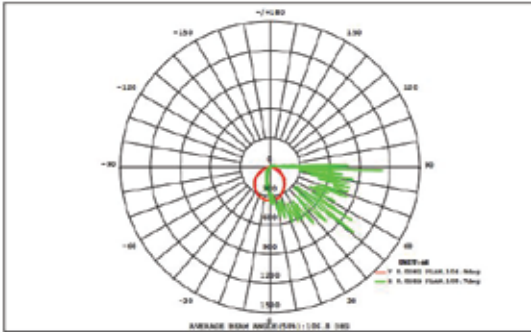

| DATA OF LAMP | | Eff: 119.20lm/W | |
|-------------------|------------|------------------|-------------|
| MODEL | ML-WPA-13W | Imax (cd) | 1332 |
| NOMINAL POWER (W) | 13W | AVAILABILITY (%) | 88.2 |
| RATED VOLTAGE (V) | 277 | Avai. FLUX (lm) | 1492 |
| NOMINAL FLUX (lm) | 1692.66 | LOR (%) | 100.0 |
| LAMPS INSIDE | 1 | TOTAL FLUX (lm) | 1693 |
| TEST VOLTAGE (V) | 277V | θ @50% (H, V) | 105, 109DEG |

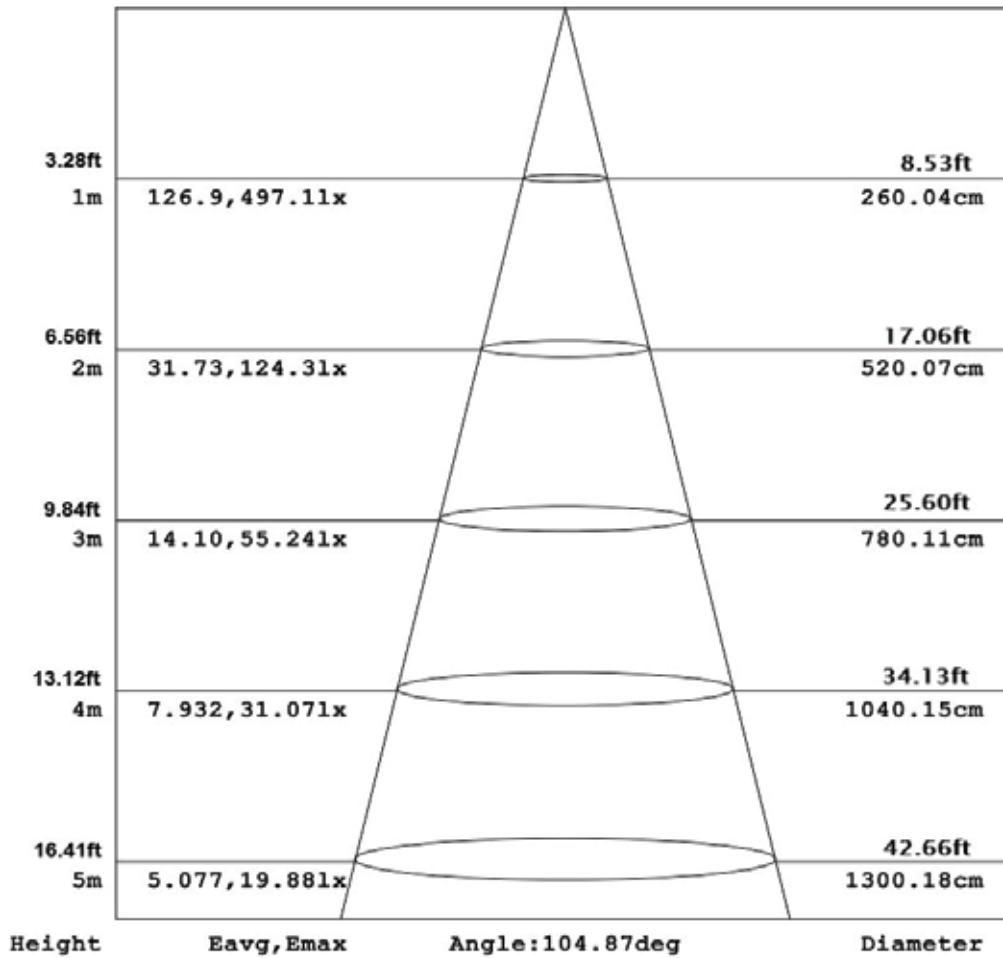

Suggested mounting height for best illumination effect: 3 to 10 feet (1 - 3 meters)



Wall Pack is widely used in pathway, hallway, perimeter, patio, entrance, stairway, house, garden, garage, yard, warehouse, factory, store, street, porch

Project Cases

