

INSTALLATION INSTRUCTIONS

SKU#101042

Product No.: FDDL-6-15W-5CCT-WH 6" LED Disc Light



← TUNABLE →
5cct
SELECTABLE
27K • 30K • 35K • 40K • 50K



WARNING

FOR YOUR SAFETY READ AND UNDERSTAND INSTRUCTIONS COMPLETELY BEFORE STARTING INSTALLATION. BEFORE WIRING TO POWER SUPPLY, TURN OFF ELECTRICITY AT THE FUSE OR CIRCUIT BREAKER BOX.

CAUTION: RISK OF FIRE

SUPPLY CONDUCTORS (POWER WIRES) CONNECTING THE FIXTURE MUST BE RATED MINIMUM 90°C IF UNCERTAIN, CONSULT AN ELECTRICIAN.

CAUTION: RISK OF ELECTRIC SHOCK

DISCONNECT POWER OR CIRCUIT BREAKER BEFORE INSTALLATION OR OPERATION.

SAFETY PRECAUTIONS

FOR SAFETY, READ AND UNDERSTAND INSTRUCTIONS COMPLETELY BEFORE STARTING INSTALLATION. ELECTRICITY SHOULD BE TURNED OFF AT THE FUSE OR THE CIRCUIT BREAKER BOX BEFORE INSTALLING THE FIXTURE. ALL ELECTRICAL CONNECTIONS MUST BE IN ACCORDANCE WITH N. E. C. OR YOUR LOCAL CODE.

ASSEMBLY INSTRUCTIONS

1. PREPARING FOR INSTALLATION: DISCONNECT ELECTRICAL POWER BEFORE INSTALLING OR SERVICING ANY PART OF THIS FIXTURE.
2. THIS PRODUCT SHALL BE SURFACE MOUNTED WITH JUNCTION BOX OR NON-COMBUSTIBLE SURFACE ABOVE 4 FEET (1.2 METER) HIGH. USER SHOULD PREPARE NECESSARY ACCESSORIES AND SPARE PARTS (NOT PROVIDED) INCLUDING JUNCTION BOX AND SCREWS.

PACKAGE CONTENTS

A
LED Disk Light



(1 pc)

B
Mounting screws



(2 pcs)

C
Wire nuts



(3 pcs)

INSTALLATION (CONSULT A QUALIFIED ELECTRICIAN BEFORE INSTALLING)

1. Connect supply wires to wires on fixture with wire nuts or push wires into Quick Connector. Connect white to white, black to black, and copper wire to copper wire as grounding connection.

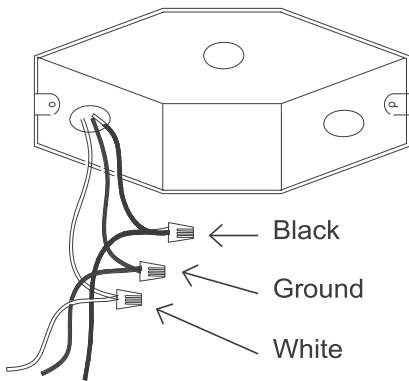

2. Completing the installation by attaching the fixture into the j-box. Attach the diffuser by twisting and lock the diffuser in place.

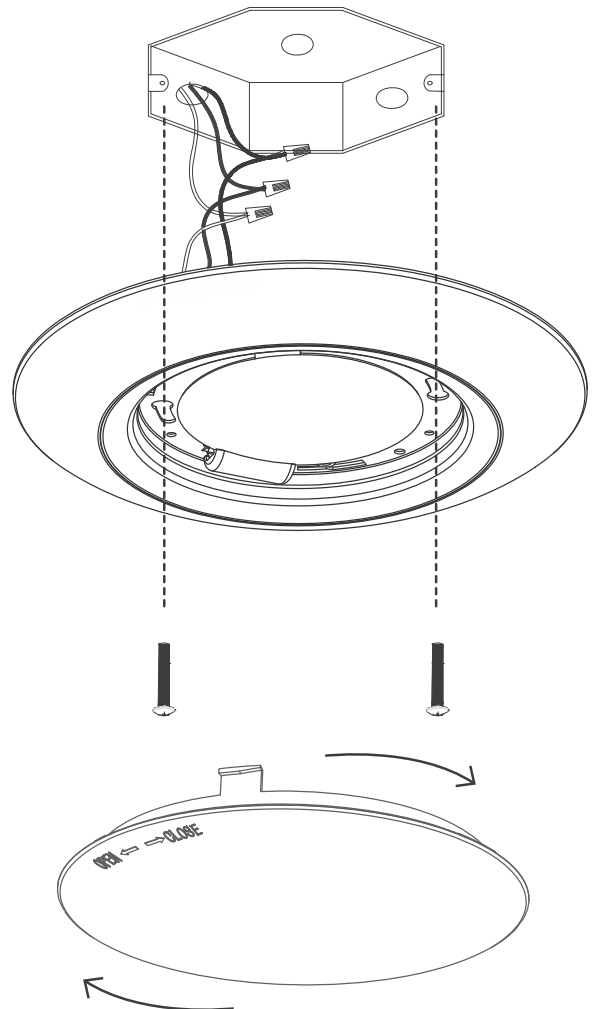

Factory Direct Lighting (2020) Ltd.
www.fdlighting.ca
Tel: 1-855-533-0743
1-905-944-1210

100 Shields Court Unit B
Markham, Ontario
Canada, L3R 9T5